

MWD SBP-10p

SMART RADAR SCANNER FOR BARRIER SYSTEMS

- Simple, convenient installation without modifying the road surface
- Reliable object detection, whether moving or stationary, in detection and safety areas of barrier systems
- Ensuring safe differentiation between vehicles and pedestrians for barrier control
- Easy set up and adaption to barrier access points and their detection areas via mobile app
- Reliable function in harsh environmental conditions



FEIG radar scanner for parking space applications and access roads

The MWD SBP-10p radar scanner is an intelligent detection device for detecting static and dynamic objects at barrier systems. Based on millimeter wave technology, this system detects both people and vehicles in defined areas and enables reliable barrier operation. Cross-traffic suppression and direction of movement detection ensure targeted passage for objects. An additional distinction is made between people and vehicles in order to allow access only to authorised objects.

The powerful radar technology and specific detection algorithms enable robustness against a wide range of weather conditions such as rain, snow and fog.

Optical feedback is provided by specific colored LEDs, visible at the device front directly. This enables status and diagnostic detection directly on the barrier system.

A secure, access-restricted Bluetooth interface is used for simple commissioning, guided setting of detection areas and further data communication by use of belonging FEIG Scanner Assistant App.

Special features:

- > Intuitive environmental teach in function and device configuration via mobile app
- > Definition of objects to be detected for barrier opening and safety area
- > Tracking of static and dynamic objects
- > Product-Lifecycle-Management, new feature updates and maintenance via Bluetooth and mobile app
- > Open cable connection for the output of 3 switching signals:
 - Open-/ Presence area
 - Safety area (further output functions adjustable)
 - 3rd output specific adjustable
 - Drive through detection, counting ETC.
- > Regularly updates for new device functions / features available and upload via APP easy possible locally
- > Data backup of config files and plant commissioning report can be saved on mobile devices locally, furthermore upload to typical clouds solutions (Microsoft, Google, Apple ETC.) possible
- > Robust compact housing with protected connection for preventing unauthorized tampering

Technical Data

Housing	Polycarbonate, Die-cast aluminum
Dimensions (w x h x d)	63.6 x 93.6 x 21.7 mm
Weight	300 g
Connection	10-pin cable 0.25 mm ² , 1.9 m
Protection class	IP65
Power supply	9 - 30 V DC
Power consumption	max. 1.8 W
Temperature range	-30° C - 55° C
Frequency range	60 - 64 GHz
Technology	mmWave-Radar, FMCW
Mounting	4 x M5 Fixing screws
Mounting height	0.3 - 0.9 m, EN 12453 protection level D: max. 0.7 m a) with mounting wedge 30° (accessory) b) directly on the barrier housing
Signal outputs	3 solid-state relays, galvanically isolated
Signal inputs	1 digital input testing
Switching voltage	max. 30 V DC / 20 V AC
Switching current	max. 100 mA
Operating status display	5 LEDs: yellow / red / yellow / blue / green
Communication interface	Bluetooth BLE 5.0
Detection range	max. 8.0 m x 8.0 m max. 6.0 m at EN 12453 protection level D
Detection angle	horizontal (azimuth) ± 60° vertical (elevation) ± 60°
Reaction times	Detection without limiting filters: 200 ms

Order information

7278.000.00	MWD SBP-B-10P Radar scanner for barriers
6773.000.00	MWD KMK030 Mounting wedge 30°
7158.000.00	MWD KMHH120 Mounting bracket 120°

Dimensions radar scanner

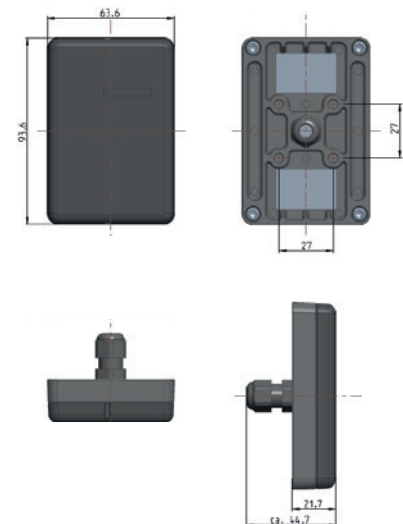

Dimensions mounting wedge 30°

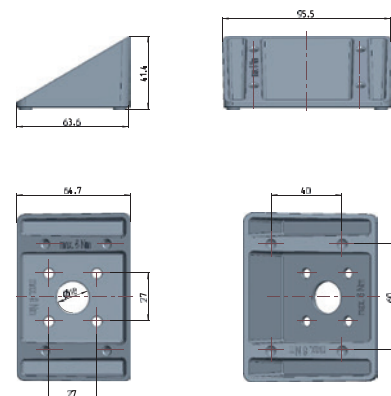

The FEIG Scanner Assistant App is available in:

